

Package Outline

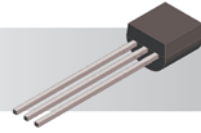

TO92

TO92

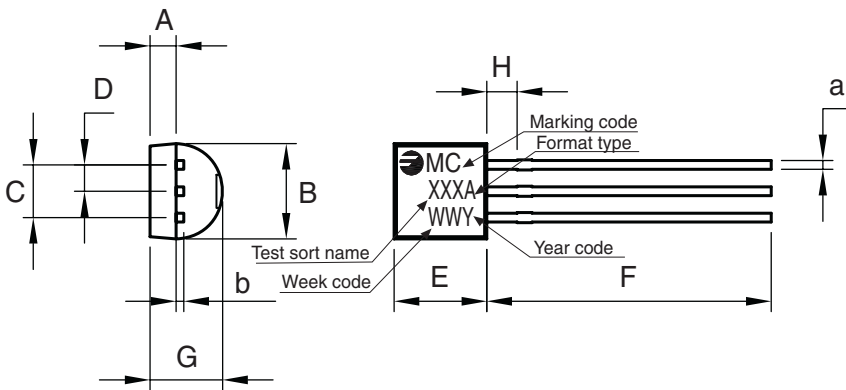

REF.	DIMENSIONS		
	Millimeters		
	Min.	Typ.	Max.
A	0.90	1.20	1.50
B	4.40	4.60	4.80
C	2.34	2.54	2.74
D	1.07	1.27	1.47
E	4.40	4.60	4.80
F	12.70	14.10	15.50
G	3.40	3.60	3.86
H	1.30	1.50	1.70
a	0.38	0.44	0.51
b	0.33	0.41	0.51

TO92 (AMMO)

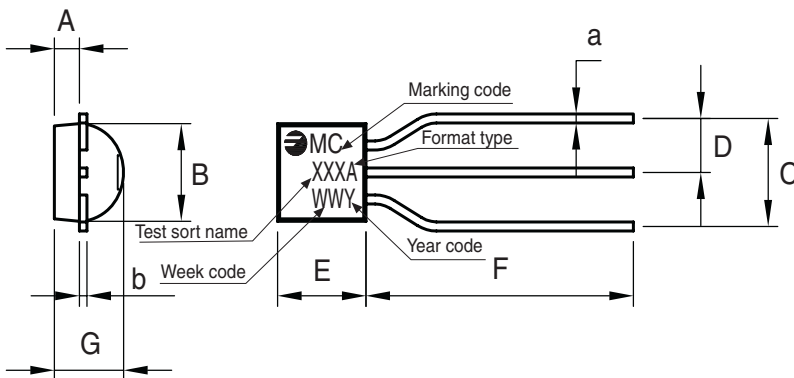

REF.	DIMENSIONS		
	Millimeters		
	Min.	Typ.	Max.
A	0.90	1.20	1.50
B	4.40	4.60	4.80
C	4.96	5.08	5.20
D	2.42	2.54	2.66
E	4.40	4.60	4.80
F	12.70	14.10	15.50
G	3.40	3.60	3.86
H	1.30	1.50	1.70
a	0.38	0.44	0.51
b	0.33	0.41	0.51