

- E** AMPLIFICADOR DE INTERIOR
- D** HAUSANSCHLUSS - VERSTÄRKER
- F** AMPLIFICATEUR D'INTERIEUR
- GB** INDOOR BROAD-BAND AMPLIFIER
- I** AMPLIFICATORE
- P** AMPLIFICADOR

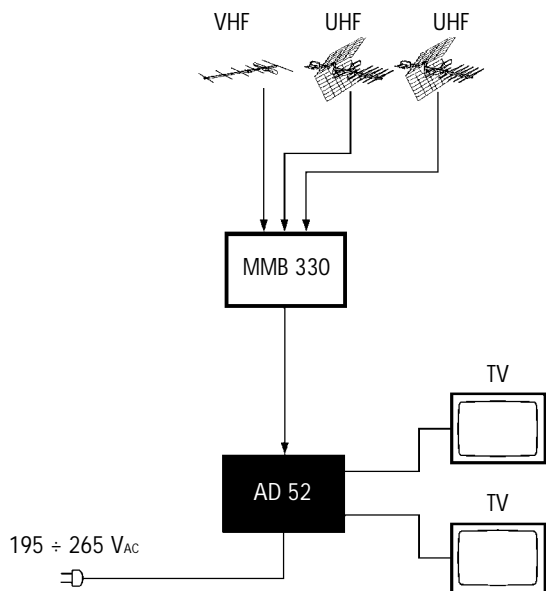

## AD 52

<b>E</b>	<b>D</b>	<b>F</b>	<b>GB</b>	<b>I</b>	<b>P</b>		<b>AD 52</b>	
Tensión de red	Netzspannung	Alimentation secteur	Mains voltage	Tensione d'ingresso	Alimentação	V <sub>ac</sub>	195 - 265	
Banda cubierta	Bandbereich	Bande couverte	Bande coverage	Bande d'ingresso	Banda coberta	MHz	VHF	UHF
Ganancia	Verstärkung	Gain	Gain	Guadagno	Ganho	dB	3 ÷ 23	23
Figura de ruido	Rauschmaß	Facteur de bruit	Noise figure	Figura di rumore	Valor de ruido	dB	2,8	
N.º de salidas	Anzahl der Ausgänge	Nbre. de sorties	No. of outputs	No. di uscite	N. de saídas		2	
Nivel máximo de salida	Maximaler Ausgangspegel	Niveau maxi de sortie	Max. output level	Livello massimo di uscita	Nivel maximo de saída	dB <sub>u</sub> V	Output 1: 104 Output 2: 94	
Impedancia de entradas-salidas	Eingangs-/Ausgangs-Impedanz	Impédance d'entrée-sorties	Input and Output impedance	Impedenza d'ingresso-uscita	Impedância de entrads-saídas	Ω	75	
Consumo	Leistungsaufnahme	Consommation	Consumption	Corrente assorbita	Consumo	W	3,5	
Temperatura de funcionamiento	Temperaturbereich	Température de fonctionnement	Operating temperature range	Intervallo temperatura di lavoro	Temperatura de funcionamento	°C	0 ÷ 50	
No abrir el equipo sin desconectar de la red eléctrica.	Vorsicht vor elektrischem Schlag. Abdeckung nicht öffnen.	Risque de choc électrique. Ne pas ouvrir.	Risk of electric shock. Do not open.	Rischio di scarica elettrica. Non aprire.	Risco de shock eléctrico. Não abrir.			



**WARNING:** When you need to change the plug, the wires of the mains supply flexible cord must not be connected to the ground terminal of a three-pin plug.

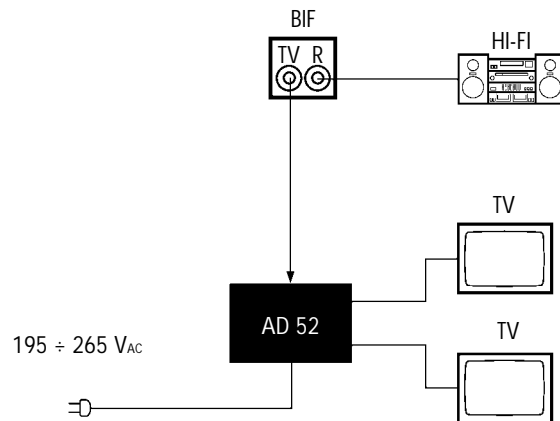

### Fagor Electrónica, S.Coop.

San Andrés, s/n.  
 E-20500 Mondragón (Spain)  
 Tel. +34 43 712526  
 Fax +34 43 712893  
 E-mail: rf.sales@fagorelectronica.es  
 www.fagorelectronica.com

